

INSIGNUM Series – Power and Precision in Marking

Reading System

INSIGNUM Scan

## INSIGNUM 3000 Scan

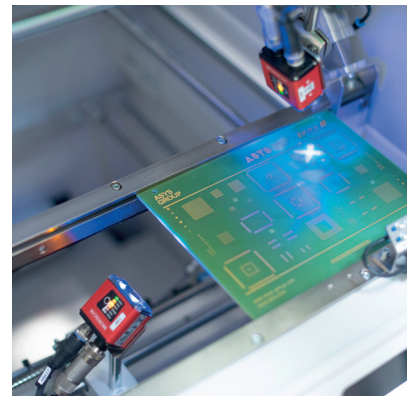
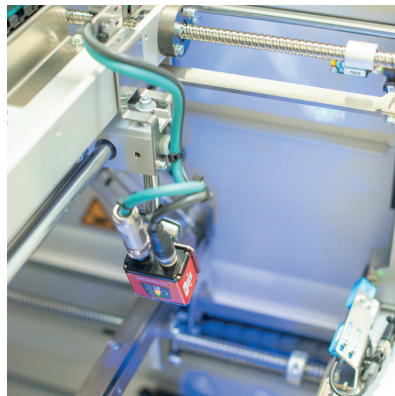

### Description

The Reading System, INSIGNUM 3000 Scan, consists of a stepper motor driven X/Y-axle-system with scanner. The product is transported on the conveyor and up against a stopper. The scanner moves into position dependent upon the product, and scans the barcode or the data-matrix code and transmits the information to the database or the network.

### Features

- \_ SIMPLEX
- \_ Multiple scan positions per product are possible.
- \_ Automatic scanner positioning
- \_ PC controlled unit

### Options

- \_ Automatic width adjust
- \_ X-Y stepper motor axes above
- \_ X-Y stepper motor axes below
- \_ Offline Programming
- \_ MES/ERP connection

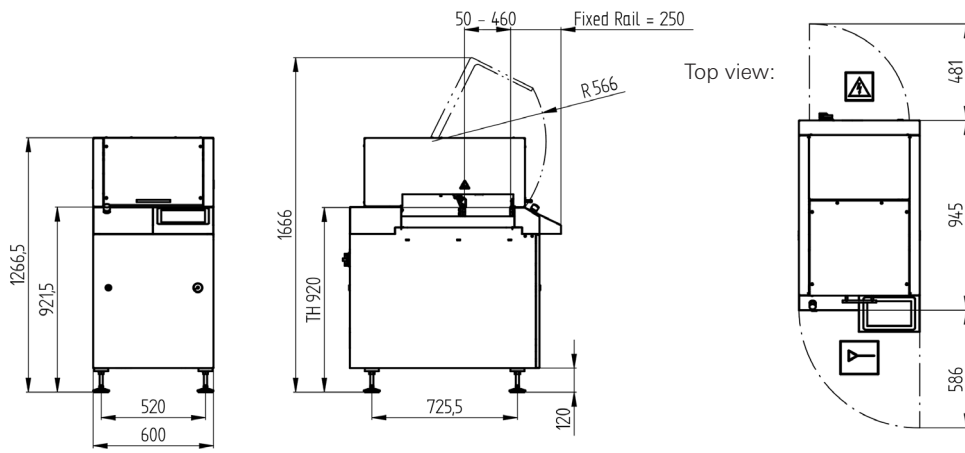

## INSIGNUM 3000 Scan

	Type 1	Type 2	Type 3
<b>Machine configuration</b>			
Transport height	920 mm ± 50 mm	920 mm ± 50 mm	920 mm ± 50 mm
Max. transport width	<b>460 mm</b>	<b>460 mm</b>	<b>460 mm</b>
Interface	SMEMA	SMEMA	SMEMA
Scan area above	300 × 400 mm	370 × 400 mm	460 × 460 mm
Scan area below	260 × 400 mm	330 × 400 mm	460 × 460 mm
Transfer direction	From left to right/from right to left	From left to right/from right to left	From left to right/from right to left
Operating side	Front of the machine	Front of the machine	Front of the machine
Fixed rail	Front of the machine	Front of the machine	Front of the machine
<b>Panel dimensions</b>			
Panel length	<b>70 to 460 mm</b>	<b>70 to 460 mm</b>	<b>70 to 508 mm</b>
Panel width	50 to 460 mm	50 to 460 mm	50 to 460 mm
Panel thickness	0.8 to 4.0 mm	0.8 to 4.0 mm	0.8 to 4.0 mm
Panel weight	to 3 kg	to 3 kg	to 3 kg
<b>Installation requirements</b>			
Power supply	230 V / 115 V, 50 / 60 Hz, ± 10%	230 V / 115 V, 50 / 60 Hz, ± 10%	230 V / 115 V, 50 / 60 Hz, ± 10%
Power supply system	L1 + N + PE	L1 + N + PE	L1 + N + PE
Power consumption	0.34 kW	0.34 kW	0.34 kW
Air supply	6 bar	6 bar	6 bar
Air consumption	5 NI/min	5 NI/min	5 NI/min
<b>Machine description</b>			
Length × width × height	530 × 950 × 1165 mm	600 × 950 × 1165 mm	790 × 950 × 1165 mm
Weight	Approx. 262 kg	Approx. 267 kg	Approx. 275 kg
Noise level	< 75 dB	< 75 dB	< 75 dB